



Document 24-313

Book 2024 Page 313 Type CORNR Pages 1

Date 1/26/2024 Time 12:48 PM

Rec Amt \$7.00

NAOMI ELLIS, RECORDER
MARION COUNTY IOWA

GA GARDEN & ASSOC.

P.O. Box 451, Oskaloosa, Iowa 52577-0451 Phone: (641)672-2526

UNITED STATES PUBLIC LAND SURVEY CORNER CERTIFICATE OF

LAND SURVEY MONUMENTS SITUATED IN SECTION 32, TOWNSHIP 74, RANGE 19,
OF THE FIFTH PRINCIPAL MERIDIAN, MARION COUNTY, IOWA.

PREVIOUSLY RECORDED IN NO CERTIFICATE OF RECORD IN COUNTY RECORDER'S OFFICE.

MONUMENT DESCRIPTION AND REMARKS:

SEE BELOW

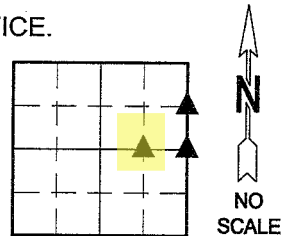

NW COR. NE-SE

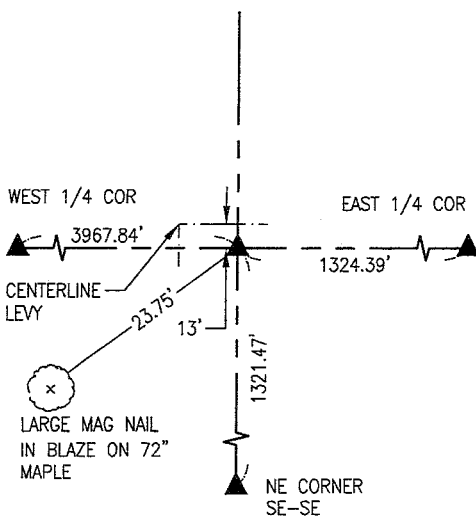

DECEMBER 15, 2023
SET 5/8" X 30" REBAR PLS #19960 AT THE MIDPOINT OF A LINE CONNECTING THE EAST 1/4 CORNER AND CALCULATED POSITION FOR THE CENTER OF SECTION 32.

EAST 1/4 COR

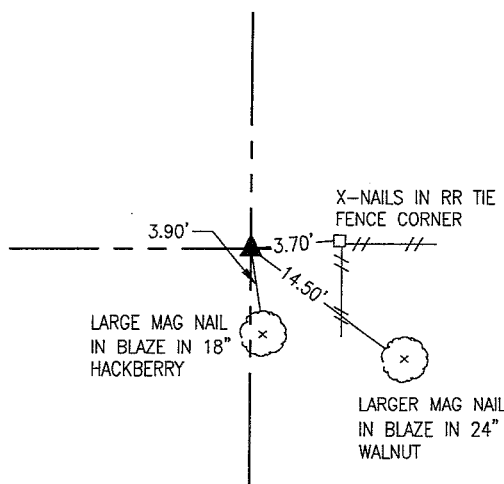

DECEMBER 15, 2023
WPA NOTES STATE A 10"x12"x18" SANDSTONE WAS FOUND AT THIS LOCATION AND A C.M WAS SET ABOVE. PROBED AROUND FENCE CORNER AND FOUND 6"x6"x10" GRANITE STONE. THIS LOCATION IS IN HARMONY WITH EXISTING FENCES AND THE WESTERLY EXTENSION OF THE SOUTH LINE OF THE SE-NW OF SEC. 33-74-19. ACCEPTED STONE AND PLACED 5/8" X 30" REBAR WITH A YELLOW PLASTIC CAP PLS# 19960 ON THE NORTH SIDE.

NE COR. SE-NE

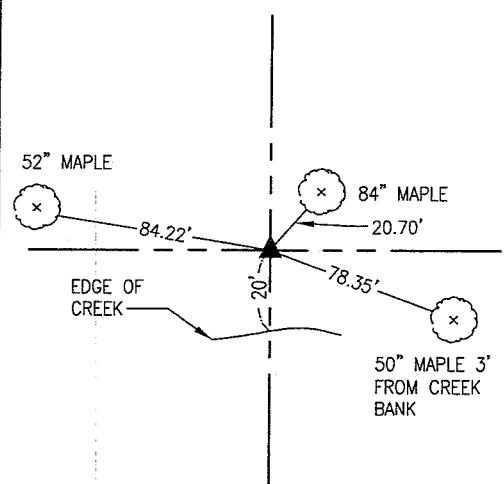

ALL TIES ARE LARGE MAG NAIL SET IN BLAZE UNLESS OTHERWISE NOTED.

DECEMBER 15, 2023
SET 5/8" X 30" REBAR PLS #19960 AT THE MIDPOINT OF A LINE CONNECTING THE EAST 1/4 CORNER AND THE CALCULATED POSITION FOR THE NE CORNER OF SECTION 32.

I hereby certify that this land surveying document was prepared and the related survey work was performed by me or under my direct personal supervision and that I am a duly licensed Professional Land Surveyor under the laws of the State of Iowa.

LIST CORNERS TO BE INDEXED

CORNERS	SECTION	TOWNSHIP	RANGE
NW COR. NE-SE	32	74	19
EAST 1/4 COR.	32	74	19
NE COR. SE-NE	32	74	19

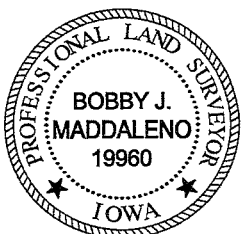

Bobby J. Maddaleno 1-19-24
Bobby J. Maddaleno, P.L.S. Date
License number: 19960
My license renewal date is December 31, 2025

Pl # 700 ck - Ret Garden Env.